



# E6

# 312T Direct Roving For Pultrusion

312T Direct Roving coated with a silane-based sizing is compatible with unsaturated polyester, vinyl ester polyurethane and epoxy resins.

Composites prepared with 312T have excellent tensile, flexural and shear properties. 312T is suitable for pultrusion process to manufacture pultruded profiles with high performance.

### Product Features

- ◎ Compatible with most thermosetting resin systems
- ◎ Complete and fast wet-out
- ◎ Good mechanical properties
- ◎ Suitable for various pultrusion process

### Identification

Glass Type	E6				
Type of Size	Silane				
Size Code	312T				
Linear Density (tex)	2400	4400	4800	8820	9600
Filament Diameter(um)	24	23	24	30	31



### Technical Parameters

Linear Density (%)	Moisture Content (%)	Size Content (%)	Breakage Strength (N/tex)
ISO 1889	ISO 3344	ISO 1887	ISO 3341
±5	≤ 0.10	0.60 ± 0.15	≥0.40

### Packaging

\* The product can be packed on pallet or in small cardboard boxes.

Package height mm (in)	260 (10)	260 (10)
Package inside diameter mm (in)	160 (6.3)	160 (6.3)
Package outside diameter mm (in)	275 (11)	310 (12.2)
Package weight kg (lb)	15.6 (34.5)	22 (48.5)

### Mechanical Properties

Mechanical Properties	Unit	Value	Resin	Method
Tensile Strength	MPa	2593	polyester	ASTM D2343
Tensile Modulus	MPa	80886	polyester	ASTM D2343

The above data are actual experimental values for E6DR24-2400-312T and for reference only.

Number of layers	3	4	3	4
Number of doffs per layer	16		12	
Number of doffs per pallet	48	64	36	48
Net weight per pallet kg (lb)	750 (1653.4)	1000 (2204.6)	792 (1746.1)	1056 (2328.1)

Pallet length mm (in)	1120 (44)		1270 (50)	
Pallet width mm (in)	1120 (44)		960 (38)	
Pallet height mm (in)	940 (37)	1180 (47)	940 (37)	1180 (47)

### Storage

Unless otherwise specified, the fiberglass products should be stored in a dry, cool and moisture-proof area. The room temperature and humidity should be always maintained at 15°C~35°C and 35% ~ 65%. It is best if the product is used within 12 months after production date. The fiberglass products should remain in their original packaging until just prior to user.

To ensure safety and avoid damage to the product, the pallets should not be stacked more than three layers high. When the pallets are stacked in 2 or 3 layers, special care should be taken to correctly and smoothly move the top pallet.

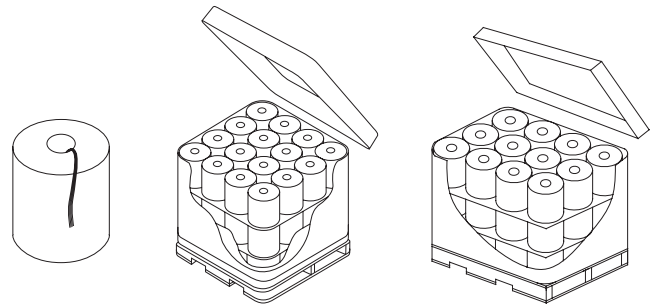

## JUSHI GROUP CO., LTD.

2011.07 版权所有：© 巨石集团有限公司 ® 巨石集团有限公司注册商标

Add: Tongxiang Economic Development Zone, Zhejiang 314500, PRC  
 Domestic Sales: +86-573-88181016 Fax:+86-573-88136222  
 Http://www.jushi.com E-mail:info@jushi.com

International Sales: +86-573-88181026 Fax:+86-573-88181058  
 Customer Service: +86-573-88181017 Fax:+86-573-88181388